

A. VEHICLE INSPECTION PROCEDURE

1. Verify that the vehicle is within the following ranges:
 - Year Range (2007-2009) Model (Mazda3 vehicles (NOT including Mazdaspeed3) and Mazda5) Produced (April 2, 2007 and November 30, 2008)
 - VIN Range: For Mazda3 (2007: JM1BK****71 742201 - 774382; All 2008; 2009: JM1BK****91 187372 - 257722) and for Mazda5 (2007: JM1CR****70 155460 - 162975; All 2008: JM1CR****80 300014 - 327437; 2009: JM1CR****90 327438 - 351393).
 - If the vehicle is within the above range, proceed to step 2.
 - If the vehicle is not within the above range, return the vehicle to the customer or inventory.
2. Perform a Warranty Vehicle Inquiry using your eMDCS System and inspect vehicle for a Campaign Label **6010H** attached to the vehicle’s hood or bulkhead. Refer to eMDCS System - Warranty Vehicle Inquiry Results table below.

NOTE: Verify Recall number as the vehicle may have multiple Recalls.

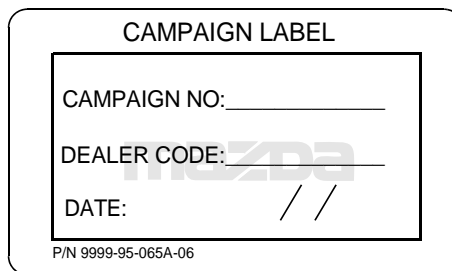
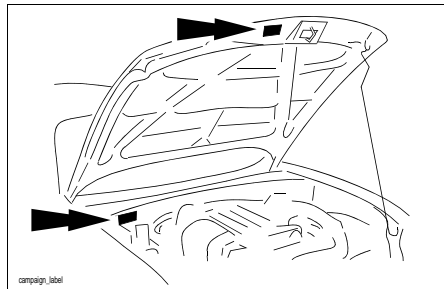

1326b

eMDCS System - Warranty Vehicle Inquiry Results

If eMDCS displays:	Campaign Label is:	Action to perform:
6010H OPEN	Present	Contact the Warranty Hotline at (877) 727-6626 to update vehicle history.
	Not present	Proceed to “REPAIR PROCEDURE OUTLINE”.
6010H CLOSED	Present	Return vehicle to customer.
	Not present	Proceed to “F. CAMPAIGN LABEL INSTALLATION”.
6010H is not displayed	Does not apply	Recall does not apply to this vehicle. Return vehicle to customer.

B. REPAIR PROCEDURE OUTLINE

1. Flush pump / lines and steering rack with 2.5 gallons (10 quarts) of BP DMV (Domestic Multi Vehicle) ATF.

CAUTION: To prevent contamination, do not use any other ATF besides the supplied 55 gallon BP DMV ATF with new drum oil pump.

2. Remove the electric power steering oil pump assembly (A) and No.1 pipe (B).

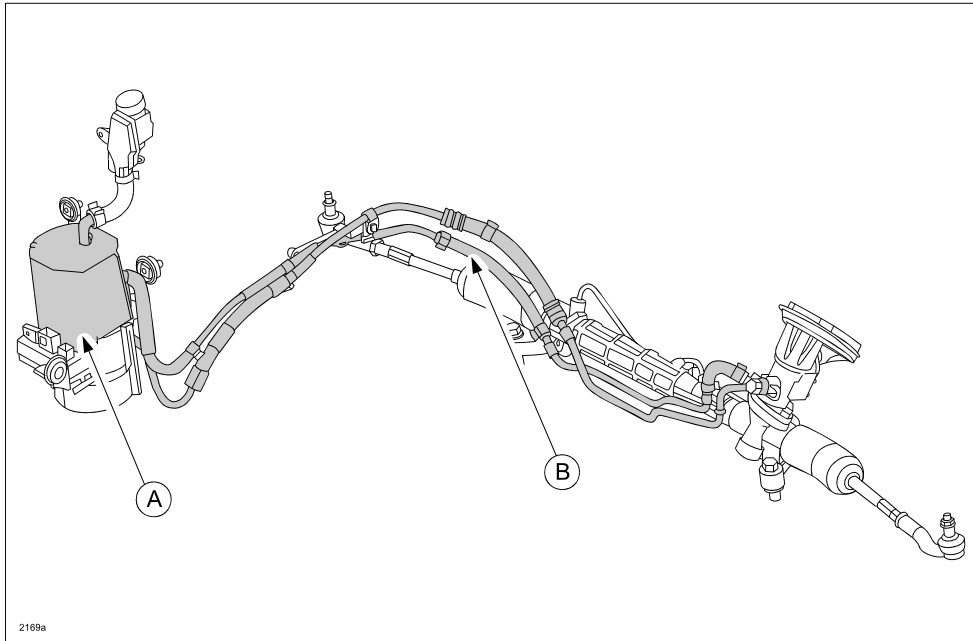

3. Replace the power steering oil pump unit (shaded part of A) on the pump assembly with oil pump kit.
4. Install the repaired power steering oil pump assembly and new No.1 pipe.
5. Fill the pump reservoir with M5 fluid and bleed air from the line.

IMPORTANT! POWER STEERING PUMP CORE RETURN PREPARATION

NOTE: Because replacement pumps are remanufactured, immediate core returns are critical to the reman process. Dealers are requested to return core pumps the same day as the repair. Every new reman pump will include a UPS Core Return Shipping Label, a blue warranty tag and a plastic shipping bag. Make sure to package the power steering pump core and deliver to your parts department immediately after repair is complete.

C. FLUSHING KIT PREPARATION

1. Remove the cap from the 5 gallon container.

NOTE: The spigot is not used for this kit. You can either keep it or discard it.

2. Drill a 5/8" hole through the center of the closed end of the cap from the back side, preferably with a step drill bit. Be careful to not damage the threads. Then clean off any loose or hanging plastic debris from the cap.

CAUTION: All small plastic particles need to be cleaned off the cap after drilling because just a fraction of contamination (about 40-50 micron) might damage the pump.

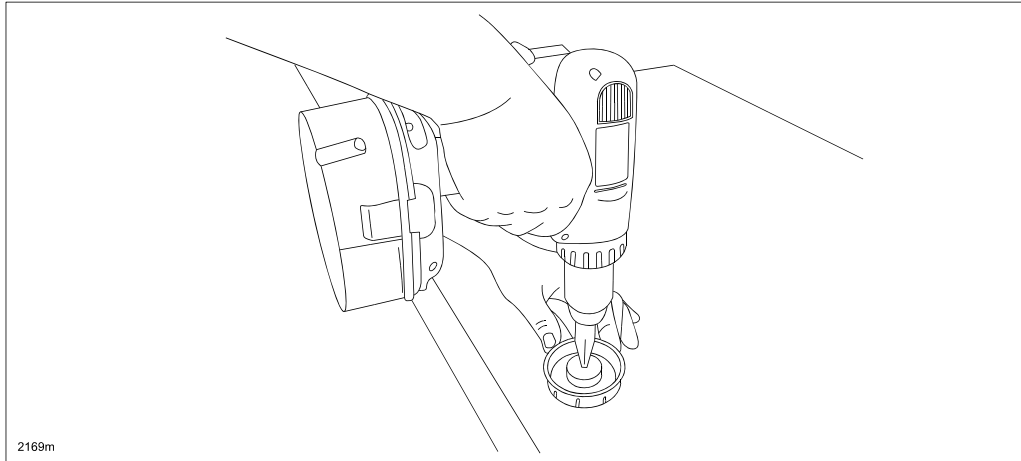

3. Wrap Teflon tape around the threads of the connector.

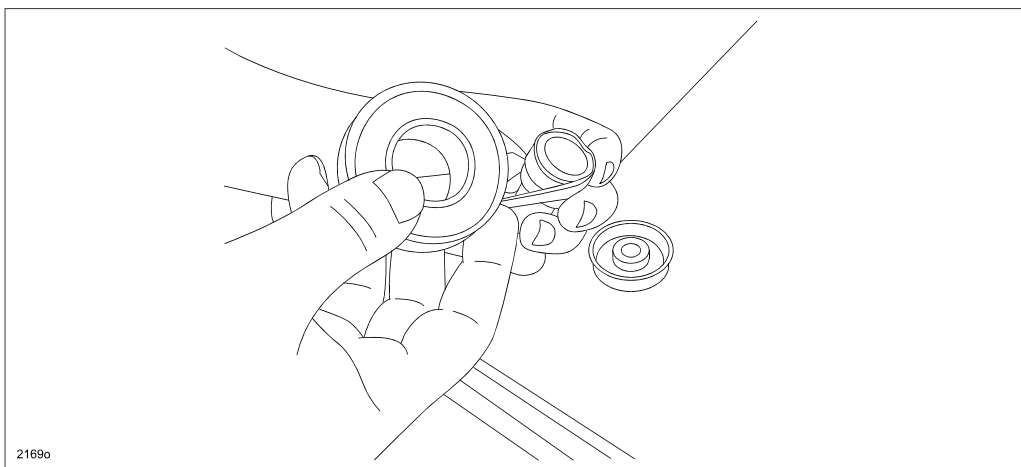

**ATTACHMENT IV
6010H**

4. Insert the threaded part of the connector into the threaded part of the cap and tighten with channel locks if needed.

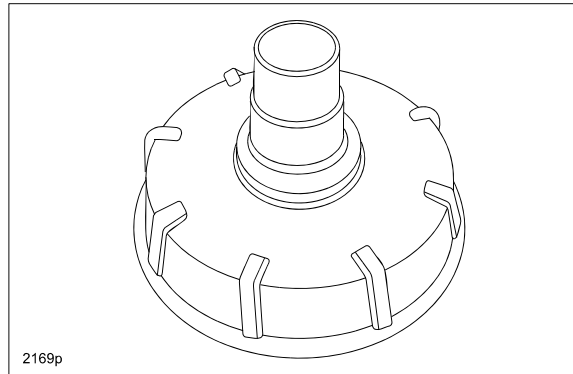

5. Attach the 5/8" vinyl hose to the connector in the cap using the supplied clamp.

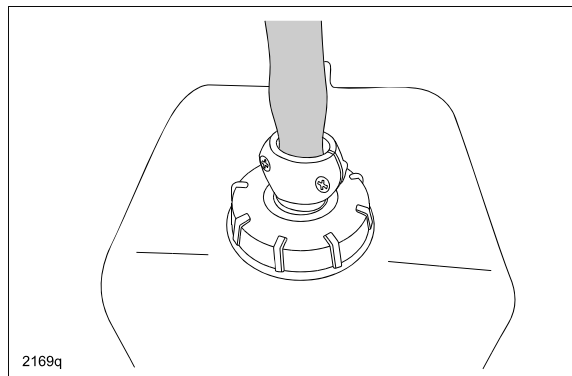

NOTE: The 1/2" vinyl hose is used as a drain hose for the power steering system – DO NOT discard.

CAUTION: Extreme care must be taken to avoid contamination of the 5 gallon container because just a fraction of contamination (about 40-50 micron) might damage the pump. Always keep the 5 gallon container opening closed using the cap fitting.

D. FLUSHING PROCEDURE

1. Raise the car on a hoist and remove the right front wheel.
2. Remove the engine side splash shield with the under cover.

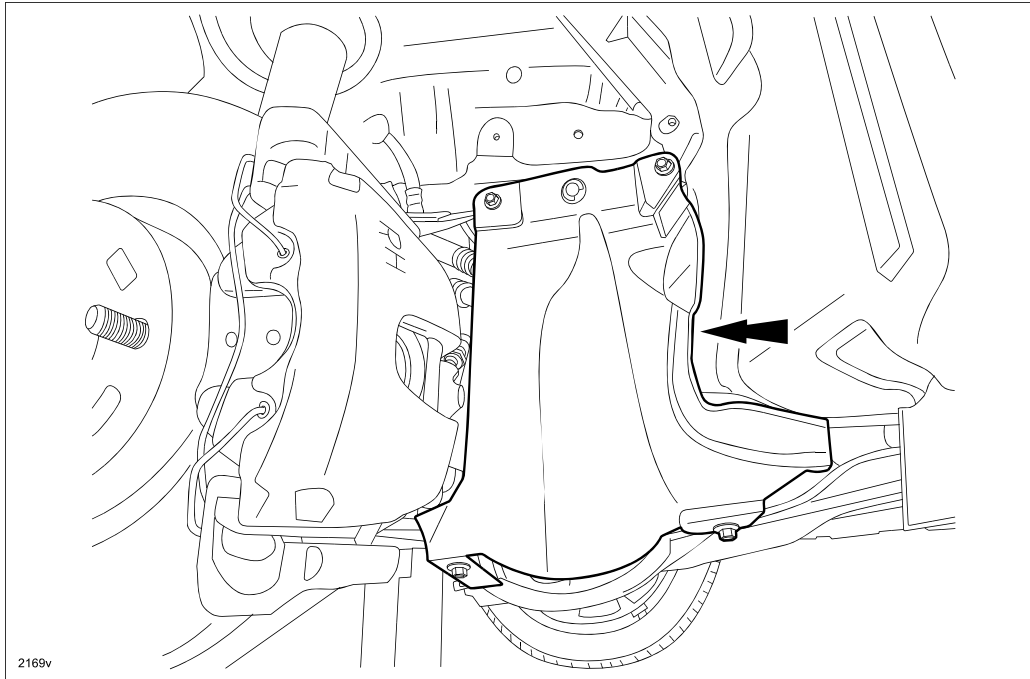

3. Disconnect the front half of mudguard then bend it backwards for working space.

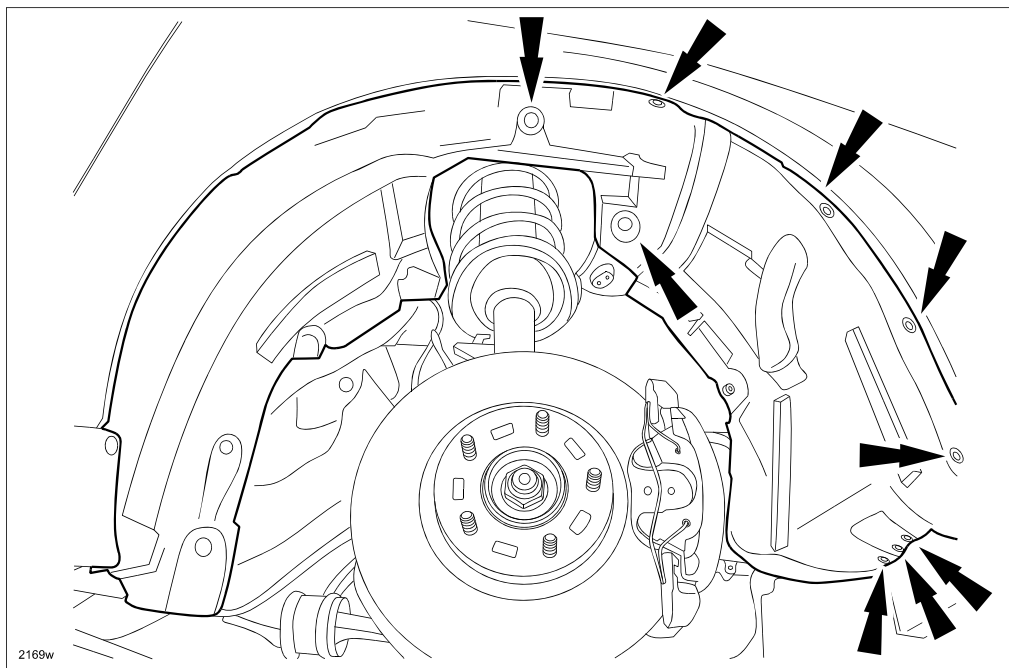

**ATTACHMENT IV
6010H**

4. Install a fender cover to protect paint, then secure the mudguard to the hood hinge using a bungy cord or rope.
NOTE: Ensure the mudguard does not contact the brakes or strut assembly.
5. Set the waste bucket or container (A) near the power steering pump.

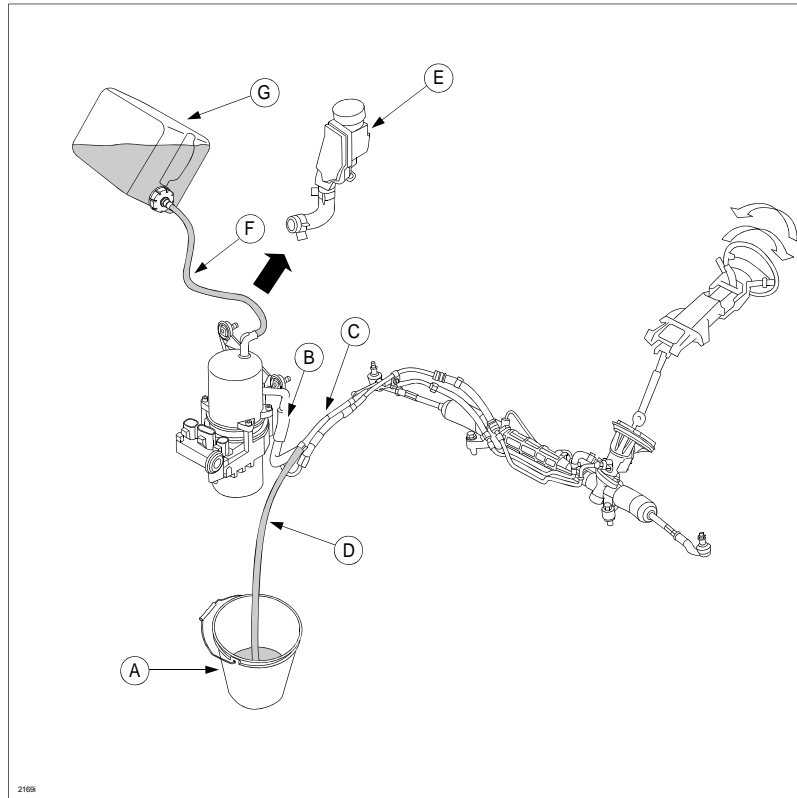

6. Remove the return hose (B) from the return pipe (C) and connect a drain hose (D) to the return pipe with a hose clamp. Rubber hose "B" should stay attached to the pump reservoir on one end, and temporarily plugged on the other.
7. Lower the vehicle (it is not necessary to set the tires on the floor).
8. Fill the 5 gallon container (G) with 10 quarts (2.5 gallons - marked on the side of the 5 gallon container) of new BP DMV ATF from the 55 gallon drum.
Power steering fluid specification: BP DMV (Domestic multi-vehicle) ATF.
CAUTION: To prevent contamination, do not use any other ATF besides the supplied 55 gallon BP DMV ATF with new drum oil pump.
9. Remove the reservoir and hose (E) from the pump.
10. Place the 5 gallon container (G) above the power steering pump, then connect the suction hose (F) to the power steering pump.

NOTE:

- It would be best to place the 5 gallon container on a transmission jack at an angle to ensure all fluid drains from the container. Position the container so that the suction hose is tilted downwards and does not kink.
- Secure the suction hose (F) with hose clamps to avoid it from disconnecting.

**ATTACHMENT IV
6010H**

11. Start the engine and turn the steering wheel back and forth to move the fluid through the gear box and the pipe assemblies. Stop the engine as soon as all 10 quarts of fluid has been used up, which can be seen in the 5 gallon container and through the clear vinyl suction hose. **DO NOT** turn the steering wheel if the fluid is gone from the container and no fluid is shown in the suction hose.

NOTE: The pump will draw 10 quarts of fluid in about 2 minutes. Within 2 minutes, turn the steering lock to lock (20 seconds each lock to lock) at least 6 times, or until the fluid is gone from the fluid container. A continuous flow of 10 quarts of fluid is required for best results.

CAUTION: Make sure **NOT** to suck any air into the power steering system while flushing, otherwise the system could be damaged. If needed, have another person stand by the 5 gallon container and make sure that the fluid is flowing smoothly during the flushing and signal when the container is empty. Make sure that the other person (driver) stops the engine before the fluid completely runs out in the container.

12. Remove suction hose (F) from power steering pump.

13. Remove drain hose (D) from return pipe (C).

14. Recycle the waste oil according to local regulations.

E. PUMP AND PIPE REPLACEMENT PROCEDURE

Outline of this procedure:

Replace the pump unit (A) of the electric power steering oil pump assembly and No.1 pipe (B), reusing the original reservoir (C) and return hose with clamp (D).

NOTE: If a new return hose comes with the pipe assembly, use the new return hose.

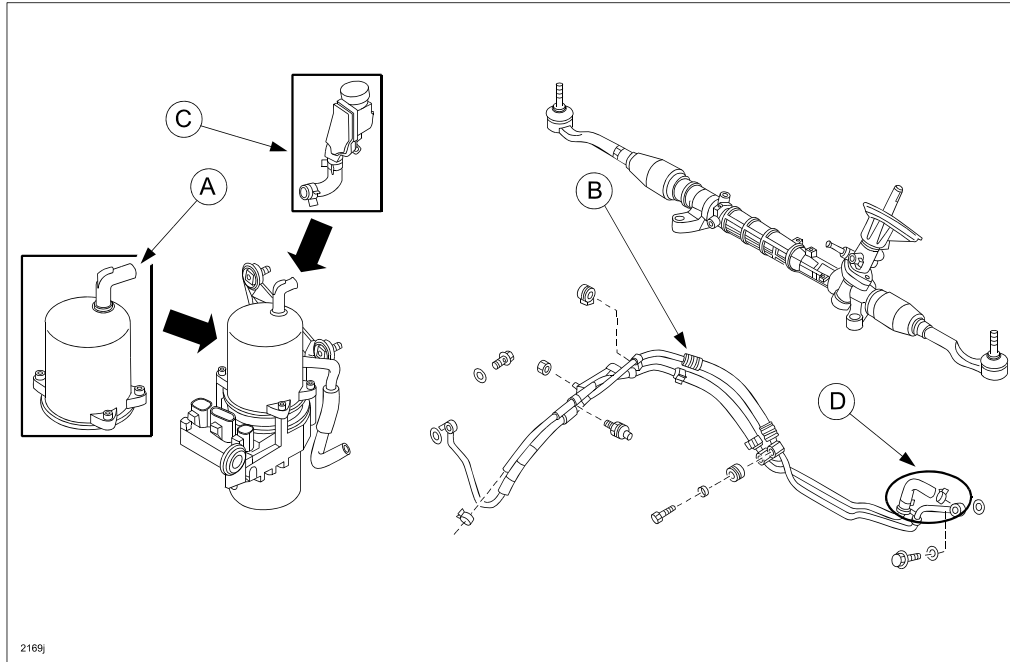

1. Remove the battery cover (if equipped).
2. Disconnect the negative battery terminal.

3. Remove the No.1 pipe assembly (B).

NOTE: Disconnect the return hose (D) from the No.1 pipe and leave it attached to the steering gear.

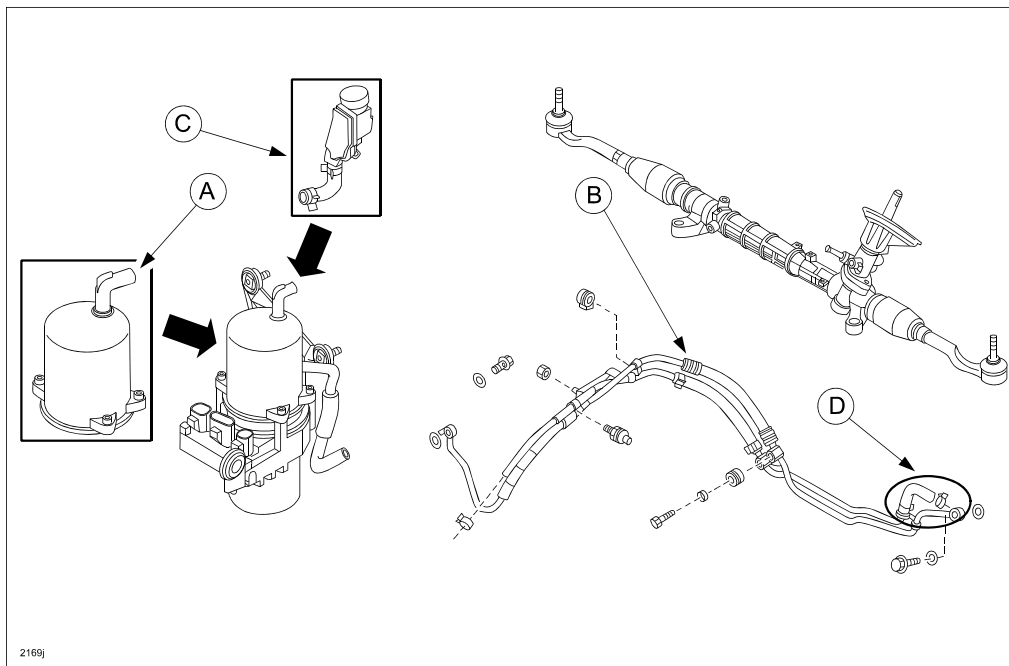

4. Remove the pump in the order indicated in the table:

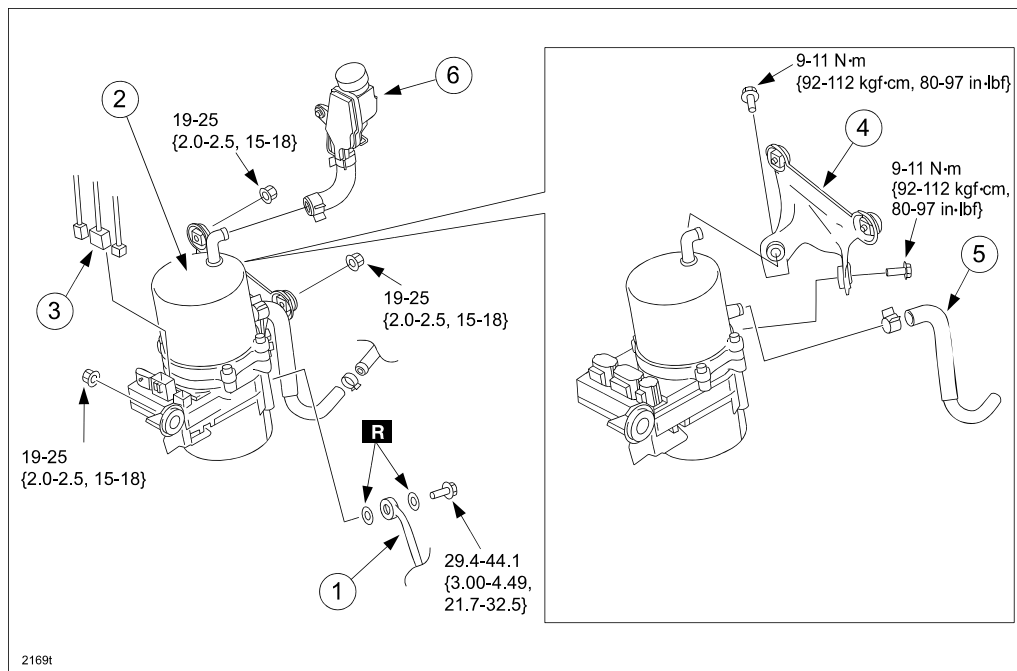

1	Pressure pipe	4	Bracket
2	Electric power steering oil pump and bracket component	5	Return hose
3	Electrical connector NOTE: The connector can be easily disconnected after the power steering oil pump and bracket component is removed from the frame and lowered.	6	Reservoir and hose. NOTE: This was previously removed during FLUSHING PROCEDURE "D". Install reservoir and hose onto pump assembly before installing complete pump / motor assembly into vehicle.

NOTE:

- It is not necessary to perform "Programmable Module Installation (PMI)" when using the Oil Pump Service Kit because the control module is not being replaced.
- Steps 6-8 are for replacement of the oil pump of the electric power steering oil pump assembly. Before performing the steps, inspect the EHPAS control module and motor visually, and replace the electric power steering oil pump assembly if a malfunction or damage is found.

CAUTION:

- The internal parts of the EHPAS control module and motor could be damaged if they receive an impact. Be careful when handling the EHPAS control module and motor to prevent it from impacting anything. Replace the electric power steering oil pump assembly if it has received an impact.
- If fluid or foreign matter enter the motor, it could damage the motor. Be careful to not allow fluid or foreign matter to enter the motor. Even if a small amount of fluid or foreign material has entered the motor, replace the electric power steering oil pump assembly.
- Do not use a vise to secure parts as the EHPAS control module or the motor could be damaged.

**ATTACHMENT IV
6010H**

5. Place the plastic protective cap over the power steering motor electrical connectors to protect the terminals.

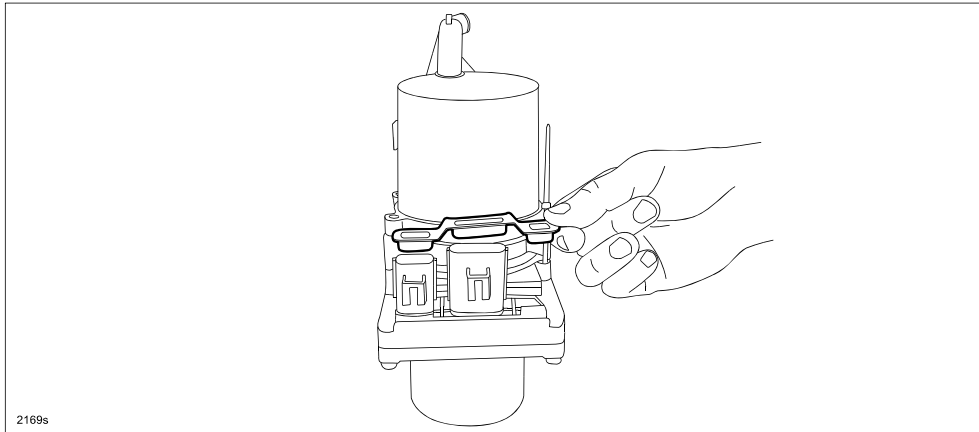

2169s

6. Drain the power steering fluid. After draining the power steering fluid, wipe off any fluid remaining around the port area of the power steering oil pump using a clean rag.
7. Disassemble in the order indicated in the figure.

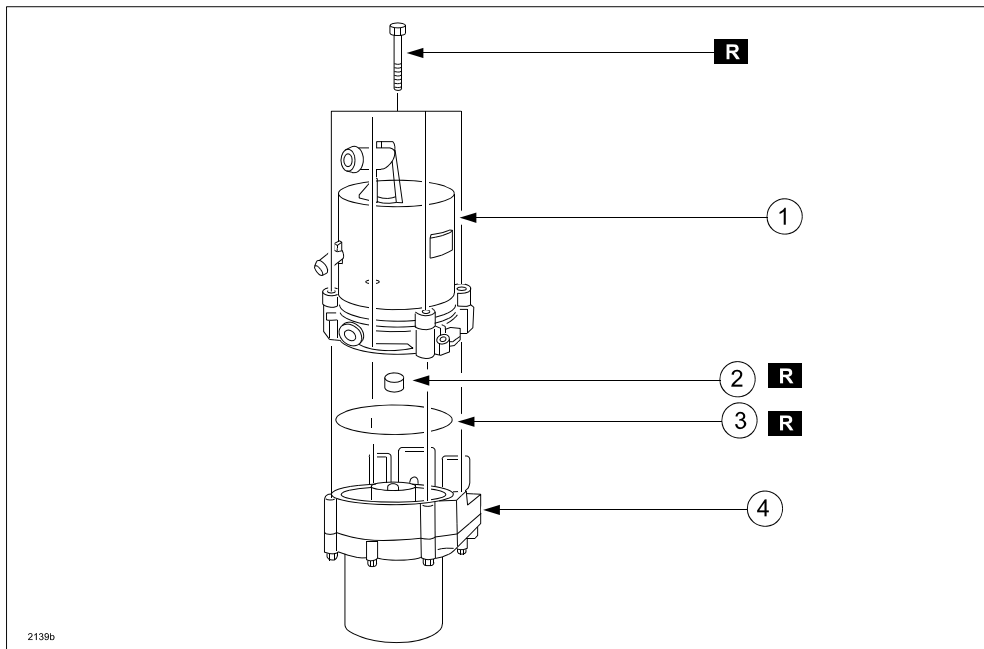

2139b

1	Power steering oil pump (See Power Steering Oil Pump Disassembly Note) (See Bushing, Power Steering Oil Pump Assembly Note)
2	Bushing (See Bushing, Power Steering Oil Pump Assembly Note)
3	O-ring (See O-ring Disassembly Note) (See O-ring Assembly Note)
4	EHPAS Control Module and Motor

8. Assemble in the reverse order of disassembly.

POWER STEERING OIL PUMP DISASSEMBLY NOTE

a. Remove the power steering oil pump installation bolts (4).

CAUTION: DO NOT remove / loosen the motor to control unit bolts. Once they are loosened, they cannot be retorqued properly. If the bolts are loosened or removed, replace the motor and control unit.

NOTE: Remove the control module and securely set on clean rags or a mat so that the EHPAS control module and motor do not get scratched.

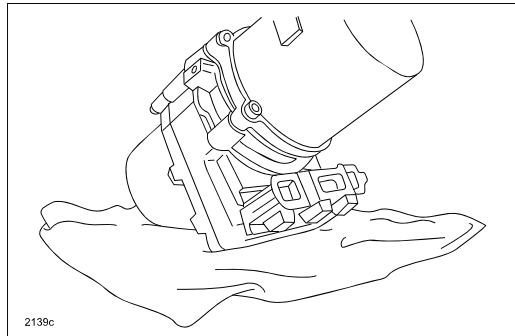

b. Remove the power steering oil pump from the EHPAS control module and motor.

CAUTION: If the pump (A) and housing (B) become separated when removing the power steering oil pump, the housing could fall and damage the part. When removing, be careful to not allow the pump and housing to become separated.

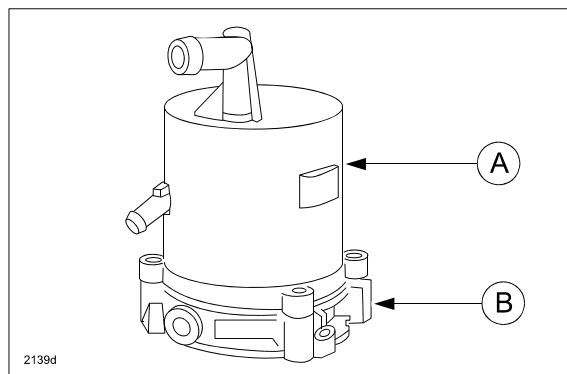

**ATTACHMENT IV
6010H**

CAUTION: Be especially careful that fluid does not get on the area shown in the figure as it could enter the EHPAS control module and motor, and then damage the motor by shorting it out when removing the power steering oil pump.

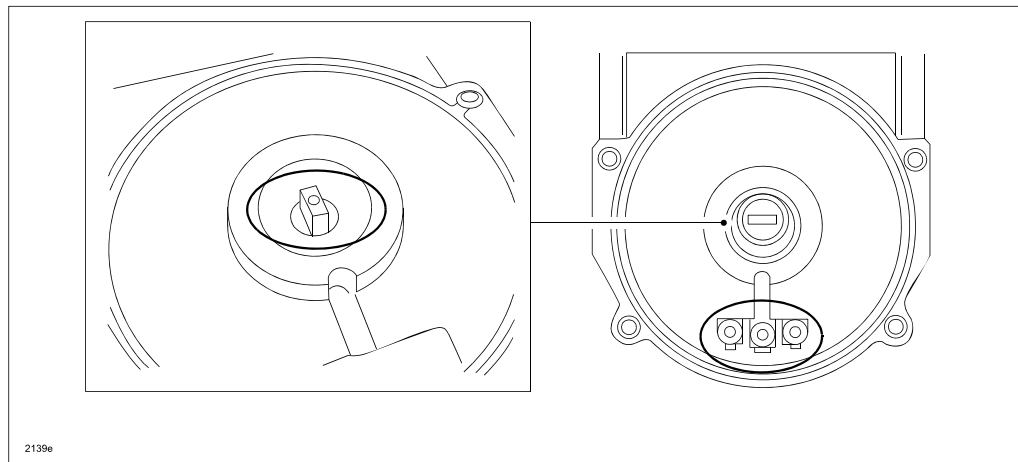

O-RING DISASSEMBLY NOTE:

- a. Remove the O-ring.

CAUTION: When removing the O-ring, do not use a screwdriver or similar tool as it could damage the O-ring installation area of the motor. If the O-ring installation area is inadvertently damaged, replace the electric power steering oil pump.

- b. Wipe off any fluid from around the oil pump installation surface of the EHPAS control module and motor using a clean cloth.

O-RING ASSEMBLY NOTE:

- a. Verify that no foreign material is adhering to the O-ring installation area and assemble the O-ring.

CAUTION: If there is foreign matter adhering to the O-ring installation area, carefully remove it so that the O-ring installation area is not damaged. If the O-ring installation area is inadvertently damaged, replace the electric power steering oil pump assembly.

**ATTACHMENT IV
6010H**

BUSHING, POWER STEERING OIL PUMP ASSEMBLY NOTE:

- a. Before assembling the bushing, verify that there is no fluid or foreign matter adhering to the oil pump installation surface of the EHPAS control module and motor. Wipe off any fluid or foreign matter using a clean cloth.
- b. Install the bushing (A) to the EHPAS control module and motor shaft (B) with the chamfer area (C) oriented to the power steering oil pump side

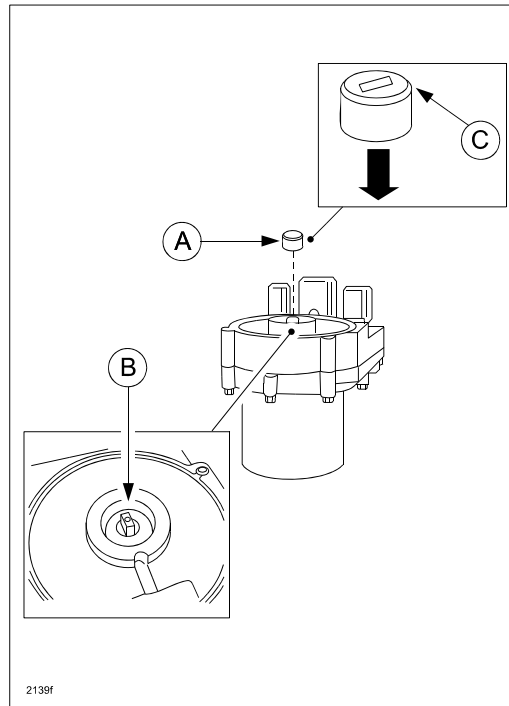

- c. Insert the pump shaft of the power steering oil pump into the bushing and temporarily install the power steering oil pump.

NOTE: The new power steering oil pump is secured to the pump and housing with a temporary band. Temporarily install it with the band left on.

- d. Rotate the pump left and right in the area shown (A) so that the pump shaft securely engages with the bushing on the motor shaft and the temporary band (B) does not contact the motor housing.

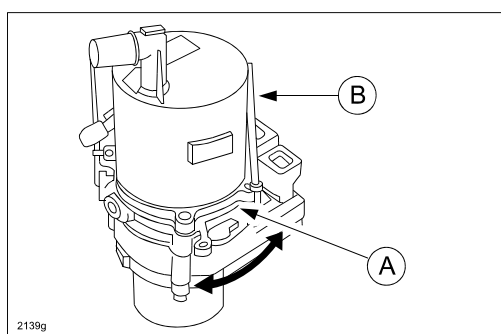

**ATTACHMENT IV
6010H**

- e. Remove the band and tighten the power steering oil pump installation bolts using a hexagonal bit socket with a bit area length of 90 mm (3.5 in.) or more (A).

Tightening torque: 7-10 Nm (72-101 kgfcm, 62-88 in-lbf)

NOTE: Install the control module with it securely set on clean rags or a mat so that the EHPAS control module and motor do not get scratched.

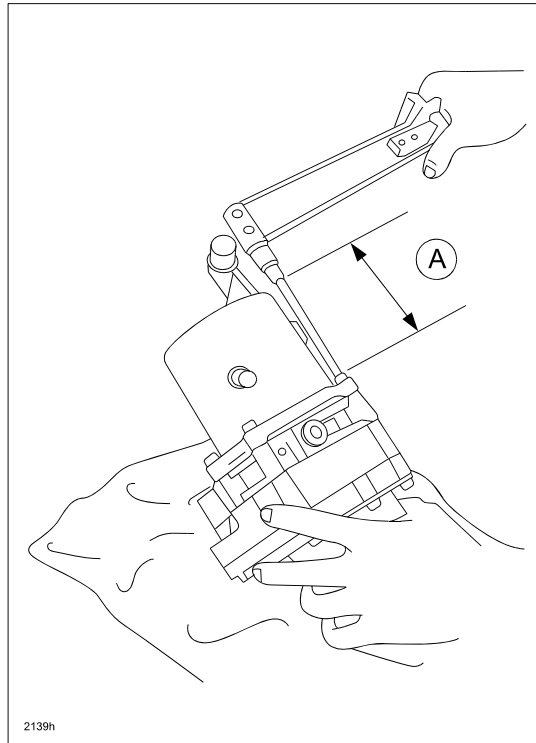

9. Remove the plastic protective cap from the power steering motor electrical connectors.
10. Install the electric power steering oil pump assembly in reverse order of removal. Refer to table in this section.

11. Install the new No.1 pipe, installing the connecting bolts (B) with new gaskets (C).

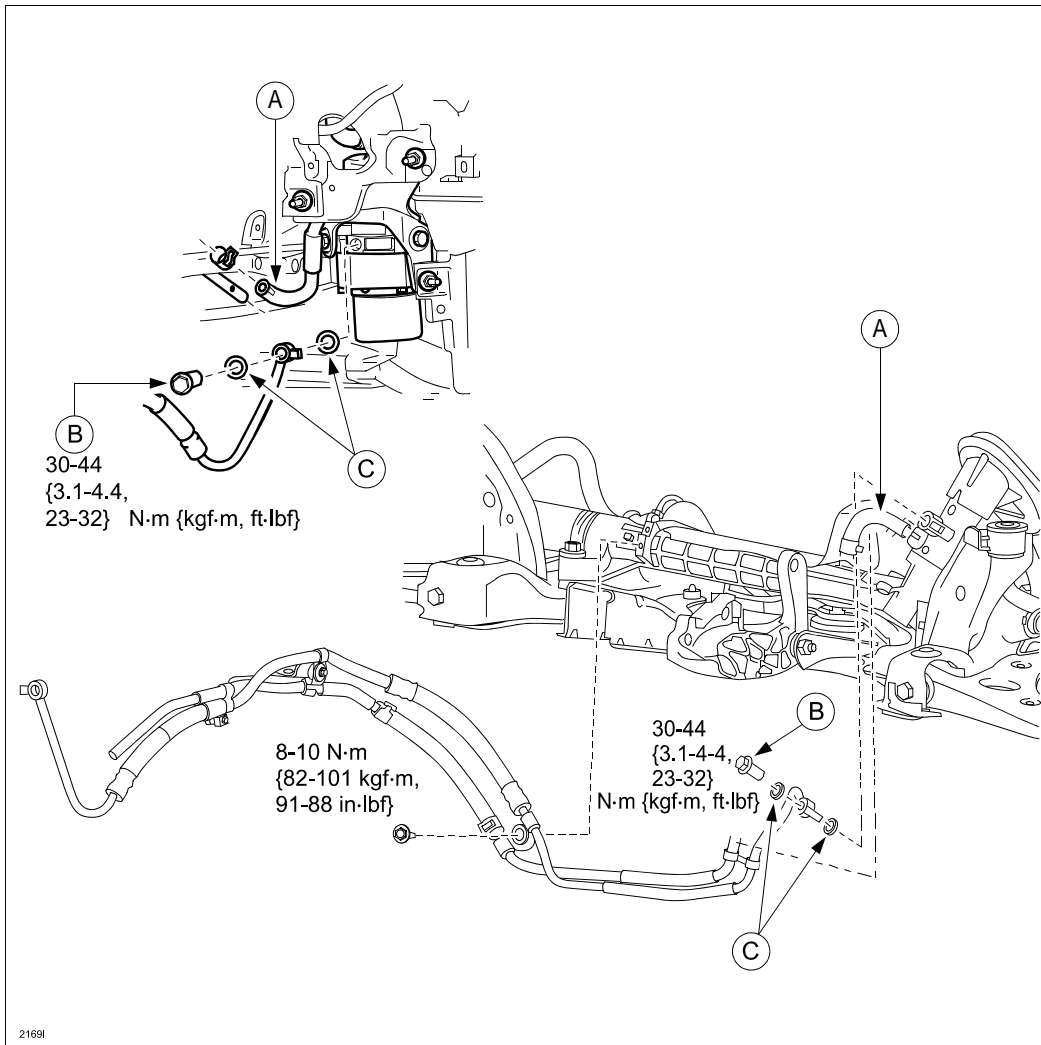

12. Attach the return hoses (A) to return pipes.

13. Refill the reservoir with power steering fluid.

CAUTION: To prevent contamination, do not use any other ATF besides the supplied 1 quart bottles of ATF M-5.

Power steering fluid specification: ATF M-5.

14. Reconnect the negative battery terminal.

15. Bleed air from the system according to Steps a–g below.

CAUTION: Do not maintain the steering wheel fully turned for 5 seconds or more. It is possible that oil temperature can rise and this will negatively affect the oil pump.

- a. Turn the steering wheel fully to the left and right several times.
- b. Reinspect the fluid level. If the fluid level had dropped, add fluid.
- c. Repeat steps a and b until the fluid level stabilizes.
- d. Start the engine and let it idle.
- e. Turn the steering wheel fully to the left and right several times.
- f. Repeat step e until the fluid is not foamy and the fluid level has not dropped.
- g. Inspect the fluid level and if the fluid level has dropped, add fluid to a level between MAX and MIN of the reserve tank.

16. Confirm the repair by starting the engine and inspecting for fluid leaks and that there is no power steering warning lamp indicator illumination on.

17. Clean any spilled fluid residue from vehicle.

18. Reinstall the front half of mudguard.

19. Reinstall the splash shield with the under cover.

20. Reinstall the right front wheel.

21. Using IDS, check and erase any stored codes.

22. Proceed to “F CAMPAIGN LABEL INSTALLATION”.

IMPORTANT! POWER STEERING PUMP CORE RETURN PREPARATION

NOTE: Because replacement pumps are remanufactured, immediate core returns are critical to the reman process. Dealers are requested to return core pumps the same day as the repair. Every new reman pump will include a UPS Core Return Shipping Label, a blue warranty tag and a plastic shipping bag. Make sure to package the power steering pump core and deliver to your parts department immediately after repair is complete.

F. CAMPAIGN LABEL INSTALLATION

1. Fill out a blue "Campaign Label" (9999-95-065A-06) with Campaign No: "6010H", your dealer code, today's date.

CAMPAIGN LABEL

CAMPAIGN NO: _____
DEALER CODE: _____
DATE: // //

P/N 9999-95-065A-06

1326b

2. Affix it to the hood or bulkhead as shown:

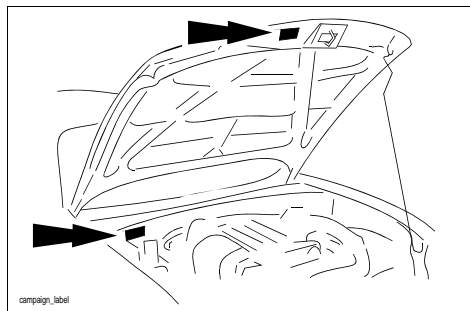

3. Return the vehicle to customer.